



RAMPART IC

M1128



**M1128[®]-RTV V2
RADIATION SHIELD
USER GUIDE**

M1128-UGD, Rev. A
LBL-087, Rev. A
Date of Issue: July 2023

This document should be stored with or within the immediate vicinity of the M1128 radiation shield and the medical team using the unit.

Rampart[®], M1128[®], Shed the Lead[®], Fight the Good Fight[®], Protect The Team[™], and You Are Worth It[™] are trademarks of Rampart^{lC}.

The M1128 radiation shield is protected in the United States under U.S. patent numbers 11,207,039 and 11,660,056. Additional patents are pending in the United States and in other countries.

The contents of this publication may not be reproduced, copied or translated in whole or in part without prior consent from Rampart^{lC}.

Pursuant to continuous product improvement, Rampart^{lC} reserves the right to change the equipment design and the technology at any time.

All rights under the copyright laws are expressly reserved by Rampart^{lC}.

Within the bounds of legal requirements, the manufacturer is only responsible for the technical safety characteristics of this device if the maintenance, repairs and modifications to this apparatus are performed by Rampart^{lC} or an approved Rampart^{lC} representative.

The Rampart^{lC} M1128 radiation shield is available in the following options:

- Mobile Right Table Version (M1128-RTV V2)

MANUFACTURER

Rampart^{lC}
Birmingham, Alabama USA
Phone: (205) 236-3000
Website: www.RampartlC.com
Email: info@RampartlC.com

LIVE TECHNICAL SUPPORT

Live technical support is available at (833) 978-0052 between the hours of 7 am to 6 pm Central Standard Time (CST), Monday through Friday. Phone calls received outside business hours will be returned as quickly as possible.

TRAINING

Training videos and a PDF version of this user guide are available at www.RampartlC.com/training.

Contents

Manufacturer	2
Live Technical Support	2
Training	2
Overview	5
Intended Use	5
Safety & Liability	5
Safety & General Symbols	6
Explanation of Symbols	9
M1128 System Overview	10
M1128 System Overview Key	11
Key Characteristics	12
Technical Specifications	12
Power Supply	12
Dimensions	13
Operating Environment	13
Weight	13
IP Protection Class	13
Identification Tag	14
Transit Mode	15
To Move in Transit Mode	16
Charging	19
LED Indicator - Battery Status	19
Instructions for Use	20
Intended User Group	20
Intended Patient Populations	20
Contraindications, Warnings and Cautions	20
Sample Configurations	22
Handset Controller	23
Resetting the Handset Controller	23
Using the M1128	24
Drape Instructions	26
Maintenance	29
Cleaning	29
Cleaning	30
Disinfection	30
Storage	31
Preventative Inspection	31
Parts and Accessories	32
Suggestions	32
Adjustable Legs	32
Under & Above Table Lower Body Protection	32
Transit Mode	32
Limited Warranty	33
Disposal	33

Overview

Congratulations on your purchase of the Rampart[®] M1128[®] radiation shield! Rampart^{IC} ensures your team is equipped with the latest, state-of-the-art radiation protection equipment and has freedom of mobility during fluoroscopic procedures. We hope you will **PROTECT THE TEAM[™]** and **SHED THE LEAD[®]** associated with lead aprons as you **FIGHT THE GOOD FIGHT[®]** in the cath lab. We think **YOU ARE WORTH IT[™]**.

This user guide provides guidance for the proper use of the Rampart^{IC} M1128 and for training personnel. Please read this document in its entirety, especially the warnings and caution statements identified throughout and summarized under *Safety & General Symbols* (see p. 6), before use.



WARNING!

To reduce risk of injury to user(s) and patient(s), user(s) must read and understand this user guide and be trained prior to using the M1128.

Note: Training videos and a PDF version of this user guide are available at www.RampartIC.com/training.

INTENDED USE

The Rampart^{IC} M1128 is a protective radiation shield intended to safeguard users from radiation exposure during fluoroscopic medical procedures. Sterile disposable drapes are placed over each individual panel and attached curtain assembly to maintain a sterile environment.

SAFETY & LIABILITY

Rampart^{IC} assumes no liability for the safe and reliable operation of the M1128 radiation protection system where:

- Installation, modifications or repairs are not performed by Rampart^{IC} technicians or people authorized by Rampart^{IC}.
- Authorized Rampart^{IC} replacement parts are not used.
- Authorized Rampart^{IC} sterility protection accessories are not used.
- The M1128 has not been installed or set up for a procedure in accordance with the steps in this user guide.
- The M1128 is not moved in accordance with steps in this user guide.
- The M1128 is moved or transported to another building location without proper moving containers and a Rampart^{IC} authorized technician.
- The M1128 is used in a manner other than its intended use as stated above.

Notice to Users: Any serious incident that has occurred in relation to the device should be reported to the manufacturer and the competent authority of the Member State in which the user and/or patient is established.

SAFETY & GENERAL SYMBOLS

Please pay special attention to important safety information marked with **WARNING**, **CAUTION** or **ATTENTION** keywords and symbols.



WARNING!

Indicates a potentially hazardous situation which could result in the *serious risk* of injury or death to the patient or operator, and/or damage to equipment or property.

- To reduce risk of injury to user(s) and patient(s), user(s) must carefully read and understand this user guide and be trained prior to using the M1128.
- Repairs must only be performed by Rampart^{IC} authorized personnel.
- Before transport, the Rampart^{IC} M1128 must be placed into *Transit Mode* (p. 15) and be disconnected from charging.
- The weight of the M1128 panels and attached curtains must not be altered in any way.
- The base unit and legs must not be altered in any way and must be used only as outlined in this user guide.
- The panels and curtains can only be adjusted up and down using the handset controller provided.
- When positioning, the panels and curtains must be carefully monitored to avoid damage to persons or property.



WARNING:
Rare Earth
Magnet

Keep rare-earth magnets away from anyone with a pacemaker and away from magnetic media. Dispose of rare-earth magnets in compliance with local, state and Federal law.



WARNING:
MR-Unsafe

The M1128 system is MR-unsafe. MR-unsafe items should not be brought into MRI scanner rooms.



WARNING:
Tipping Hazard

- **CONFIGURATION DURING USE:** The M1128 panels and attached curtains can be placed safely at any needed angle during use, *so long as one leg is positioned in the general direction of each panel and curtain* to provide proper weight distribution and stabilization of the equipment, and to prevent the equipment from tipping.
- **CONFIGURATION DURING TRANSIT:** To move the M1128 to another location, the M1128 must be placed into *Transit Mode* (p. 15). First, the mast must be collapsed to the lowest position and the panels and attached curtains folded together and locked forward between legs 1 and 4. Then, all four legs should be positioned for Transit with leg locks locked into place to prevent legs from changing angle during transit. The person moving the device should carefully walk on the side of the device with Rampart^{IC} logo to push and guide the M1128 during transit. When in Transit Mode and moved correctly, the M1128 is narrow enough to fit through standard walkways.



WARNING:
Radiation
Exposure

- Failure to set M1128 lead-equivalent acrylic panels and curtain attachments at the proper height and position may cause radiation exposure. The M1128 is designed to be used with under-table and above-table lower body protection.
- According to the *Expert Consensus Document on Optimal Use of Ionizing Radiation in Cardiovascular Imaging*¹, proper radiation protection is in place when a minimum of 0.5 mm lead equivalency is placed between the radiation source and medical personnel. When used correctly, the RampartIC M1128 panels provide a protection level of 1 mm lead equivalency and the curtains provide 0.5 mm lead equivalency against radiation exposure.
- The panels and curtain attachments must be handled with care so they are not damaged due to contact with other objects. If the panels or curtains are damaged, they must be rechecked according to the *Maintenance* section on page 29 of this user guide.



CAUTION:
Pinch Point

When making final adjustments to the panels and curtains, and while the patient is in position, always monitor the lower edge of the panel and curtain in relation to the patient to prevent injury. Always maintain visual contact with panels, curtains and other equipment, in relation to the patient, when panel and curtain assemblies or other equipment are being adjusted.



CAUTION:
Heavy
Equipment-
Injury Risk

- The M1128 is heavy and caution must be used when handling the system.
- Failure to maintain control when moving the system can result in personal injury or property damage.
- Personnel working with the M1128 system(s) must be properly trained.
- M1128 assembly, repairs and maintenance may only be performed by RampartIC personnel or people authorized by RampartIC.

The M1128 acrylic panels and curtain attachments will be permanently damaged if cleaned with abrasive cleaners. **When cleaning acrylic panels and curtain attachments, DO NOT use the following cleaning supplies:**

- Alcohol wipes or Sporicidan² disinfectant towelettes, rough or abrasive-faced sponges, brushes, cleaning pads, scrapers, or metal tools, paper towels, linen washcloths
- Strong detergents or abrasives such as scouring powders
- Aerosol cleaners with Butyl Cellosolve³
- Hydrocarbon or chlorinated solvents, ammonia (more than 0.5%), or strong alkali cleaners
- Cleaners that are designed for grease cutting
- Excessively hot water or steam

ATTENTION!
(Without safety
alert symbol)

1 J. W. Hirshfeld and V. A. Ferrari, "2018 ACC/HRS/NASCI/SCAI/SCCT Expert Consensus Document on Optimal Use of Ionizing Radiation in Cardiovascular Imaging: Best Practices for Safety and Effectiveness," 2018, <http://www.onlinejacc.org/content/early/2018/04/30/ajacc.2018.02.016> (accessed August 10, 2019).

2 Sporicidan® is a registered trademark of Contec, Inc.

3 Butyl Cellosolve™ is a trademark of the Dow Chemical Company.

Indicates a potentially hazardous situation which could result in a *minor or moderate risk* of injury to the patient or operator, and/or damage to equipment or property.



CAUTION!





















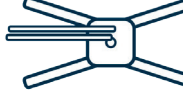

- The M1128 must be fully charged at least once every 12 months.
- The M1128 must be charged a minimum of 10 hours to obtain full charge. Please see [Charging](#) on page 19.
- Locking the casters during a procedure may cause damage to the M1128 or interfere with its proper use.
- When cleaning acrylic panels and curtain attachments, never use rough or abrasive sponges, steel wool, brushes or cleaning pads.
- When cleaning any component of the M1128, never use scrapers or metal tools of any kind.
- Potential drag may occur when the radiation shielding curtains are moved during a procedure. Ensure that the curtain flaps are lying flat against the patient's abdomen, pointing towards the patient's head, to allow for best visibility and intervention to access points.



CAUTION:
Trip Hazard

- Place controllers and the M1128 legs in a convenient and safe position so as not to create a tripping hazard for the physician and medical team in the lab.
- Always maintain awareness of the positioning of M1128 legs and casters to avoid tripping when moving around the M1128.
- CONFIGURATION DURING TRANSIT: To avoid becoming a tripping hazard, the M1128 must be placed into [Transit Mode](#) (p. 15). First, the mast must collapse to the lowest position and the panels and curtain attachments folded together and locked forward between legs 1 and 4. Then, all four legs should be positioned for Transit with leg locks locked into place to prevent legs from changing angle during transit. When in Transit Mode, the M1128 is stable and narrow enough to fit through standard walkways. The person moving the device should carefully walk on the side of the device with the Rampart^{IC} logo to push and guide the M1128 during transit.

Explanation of Symbols

	Reference Number		Use By
	Serial Number		Keep Dry
	Quantity		Instructions for Use Found at www.RampartIC.com
	Batch Number		Complies with Applicable European Union Regulations
	Manufacturer		Prescription User or Licensed Healthcare Practitioner Use Only
	Manufactured Date	Transit Mode	
	Medical Device	Mast in the lowest position Panels folded together and locked Legs in transit position and locked	
	Do Not Re-Sterilize		
	Do Not Use If Package is Damaged	1 2 3 4 Leg Number (1-4)	
	Do Not Reuse		
	Sterilize Using Ethylene Oxide	European Authorized Representative	
	Leg 1 Angle Indicator (Transit to 45°)		Leg 2 Angle Indicator (Transit to 45° to 90°)
	Leg 3 Angle Indicator (Transit to 45°)		Leg 4 Angle Indicator (Transit to 45°)
	Lower Rotation Lock (Lock for Transit, Auto-Lock, Unlock)		Upper Rotation Lock (Lock for Transit, Auto-Lock, Unlock)

M1128 SYSTEM OVERVIEW

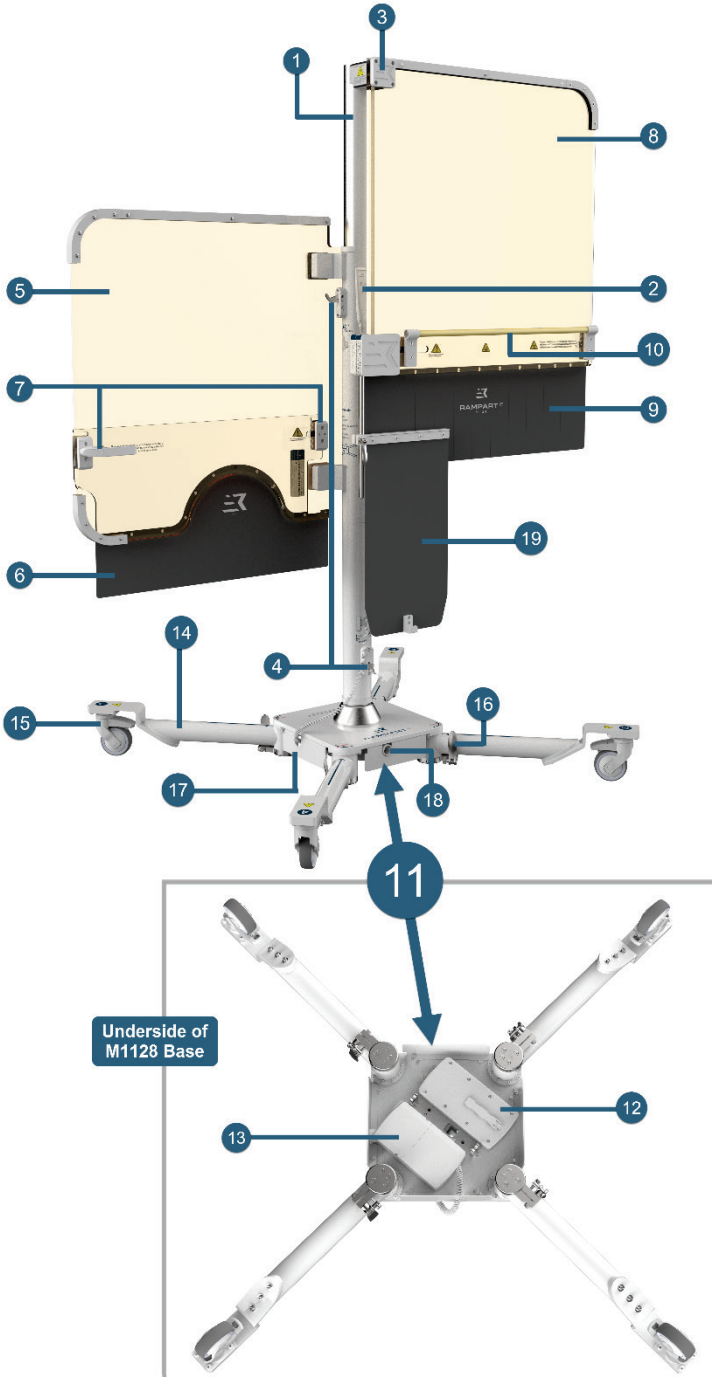

M1128 System Overview Key

1	Telescopic Mast: This stainless-steel mast is the backbone of the M1128, supporting the weight and height adjustment of all attached panels and curtains by control of the handset controller. The total height of the M1128 can be adjusted between 65.7 inches (1669 mm) tall when the mast is fully collapsed and up to 95.2 inches (2419 mm) tall when the mast is fully extended.
2	Handset Controller: Controls the simultaneous up and down movement of the panels and curtains attached to the mast: <ul style="list-style-type: none"> • <i>Top buttons</i> – raise and lower both the radial and lower extremity panels simultaneously. • <i>Bottom buttons</i> – raise and lower the lower extremity panel attached to the mast.
3	Panel Mounting Brackets: Durable, acetal plastic brackets of varying shapes are used in M1128 assembly of the panels and shelves, curtains and handlebar.
4	Rotation Locks: The M1128 comes with two rotation locks: <ul style="list-style-type: none"> • An upper rotation lock which locks and unlocks the movement of the lower extremity panel and curtain • A lower rotation lock which locks and unlocks the movement of the radial panel and curtain
5	Radial Panel: Adjustable acrylic panel with a half circle arm cutout and 1 mm lead-equivalent protection. This is one of the two large primary radiation shielding panels motorized for movement via attachment to the mast assembly.
6	Radial Curtain: Pliable curtain with 0.5 mm lead-equivalent protection which attaches to the radial panel and provides flexible, shapeable radiation protection by conforming to a patient's body.
7	Radial Panel Handle and Radial Panel Bracket: A fixed handle and bracket attached to the radial panel. These parts are designed to better facilitate manipulation and positioning of the M1128.
8	Lower Extremity Panel: Adjustable acrylic panel with 1 mm lead-equivalent protection. This is one of the two large primary radiation shielding panels motorized for movement via attachment to the mast assembly.
9	Lower Extremity Curtain: Pliable curtain with 0.5 mm lead-equivalent protection which attaches to the lower extremity panel.
10	Handlebar: A handlebar attached to the lower extremity panel aids in steadying and positioning the M1128.
11	Base Block: The base of the M1128 comes with four configurable base legs and four base access panels which can swing open to provide access to components in the base. The rechargeable battery, charging cord and the controller are attached on the underside, and the telescopic mast on top.
12	Rechargeable Battery: The rechargeable battery is attached under the base block for mobile operation. It requires a minimum of 10 hours to fully charge and can remain charging when not in use without damaging the battery. The battery must be charged once every 12 months.
13	Controller: The control box located under the M1128 base receives input from the handset controller to raise or lower the panels and curtains attached to the mast.
14	Base Legs: The base legs are mounted to the M1128 base, adjusts to a variety of configurations and can fold inward to create a minimal footprint for <i>Transit Mode</i> (p. 15) or <i>Storage</i> (p. 31.)
15	Lockable Casters: Industrial grade, smooth-rolling casters attached to each leg of the M1128 allow smooth configuration of the base legs, transportation of the M1128, and are lockable.
16	Leg lock: There are four leg locks, one on each leg. Unlock the individual leg lock on each leg to reposition legs. Lock to keep legs from changing positions.
17	Base Access Panels: There are four base access panels, one on each vertical side of the base that swing open and closed to allow access to M1128 base block contents.
18	Charging Port: Connects the rechargeable battery and controller under the base to the wall outlet.
19	Center Mast Accessory (CMA): The CMA assembly includes a pliable, articulating 1 mm lead-equivalent protection CMA curtain able to adjust in height along a CMA guide shaft and lock into place via the CMA clamping handle , all of which are attached to the lower extremity panel via the white box-shaped CMA mounting bracket . A curtain hook on the bottom of the CMA curtain is used to fold up the curtain for <i>Transit Mode</i> (p. 15) or <i>Storage</i> (p. 31).

KEY CHARACTERISTICS

- Acrylic panels with a full 1 mm of lead-equivalent protection rotate smoothly around the mast to provide customized protection for most approach positions including bilateral radial, bilateral femoral and bilateral pedal.
- Panels are adjustable vertically to adapt to table and physician height, by use of a handset controller.
- Pliable radiation shielding curtains able to conform to patient body shapes attach to the bottom of the radial and lower extremity panels and extend the M1128 protective coverage area.
- The CMA assembly provides height-adjustable articulating radiation protection between the radial and lower extremity panel.
- The M1128 legs are also adjustable to fit most intervention procedure tables.
- The M1128 panels and curtains remain sterile when properly draped.
- The M1128 panels and curtains can be configured into an efficient mobile or storage position when not in use.
- A below-table lead-equivalent protective modular shield, is available for purchase through RampartIC, and can be used with the M1128 to provide further radiation protection to the physician and lab tech on the shielded side of the table.

TECHNICAL SPECIFICATIONS

Power Supply

The M1128 uses a rechargeable nickel manganese cobalt lithium-ion oxide battery attached to the underside of the M1128 base.

- 25.9 VDC output voltage
- 10 A maximum discharge current
- 300 mA charging current
- 2.25 Ah / 58.28 Wh battery capacity
- IPX6 washable protection class
- 10-hour full battery charge time
- 10.5 feet (3.2 meter) cord length

ATTENTION! The M1128 must be fully charged at least once every 12 months.

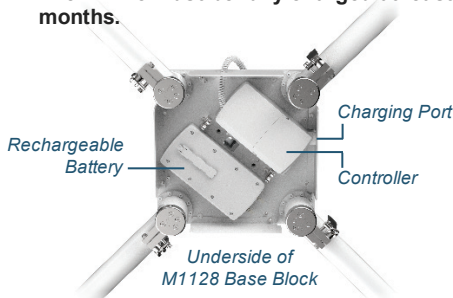

Dimensions

The four legs, extendable mast, acrylic panels and attached radiation shielding curtains of the M1128 can be configured in a variety of ways with the overall measurements varying accordingly:

- *Instructions for Use* (p. 20)
- *Transit Mode* (p. 15)
- *Maintenance* (p. 29)

The M1128 at its **maximum dimensions** is positioned with both upper and lower mast actuators extended, panels positioned at a 180-degree angle, and a leg positioned generally under each panel and attached curtain. This configuration allows for proper weight distribution and balance while the M1128 is at its largest configured size: 95.2 inches (2419 mm) tall by 70 inches (1778 mm) wide

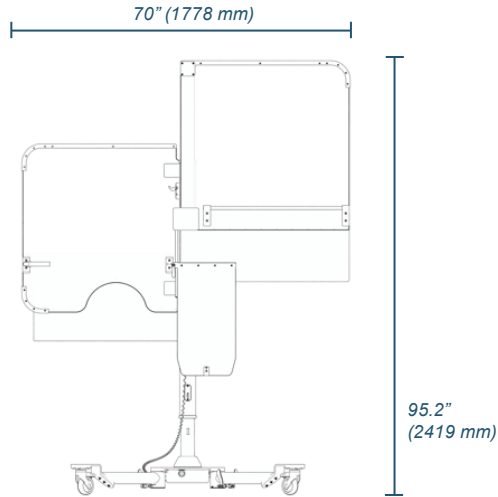

Operating Environment

The M1128 system is designed for indoor use and storage only and must not be subjected to weathering, UV light or corrosive environments. The working environment defined for this device is a clinical or hospital surgical suite with a working temperature range of 50°F (10°C) to 77°F (25°C) at 20% to 75% non-condensing humidity. Storage temperature is between 14°F (-10°C) to 104°F (40°C).

Weight

- The assembled M1128 radiation shield is over 300 pounds (>136 kg).
- The M1128 handset controller is 1.10 pounds (0.5 kg).

IP Protection Class

The M1128 radiation shield is rated in the IPX6 washable protection class.

IDENTIFICATION TAG

An identification tag can be found at the base of the M1128 identifying key information about your product that may need to be referenced during service calls.

- Product Name
- Reference Number
- Serial Number
- Bar Code
- Manufacturer Name
- Manufacturer City, State and Zip
- Manufacturer Website
- Manufacturer Phone

Transit Mode

The M1128 radiation shield must be placed into Transit Mode to be safely and efficiently moved. Transit Mode consists of configuring the M1128 to its smallest profile while maintaining stability. When in Transit Mode, the M1128 upper and lower mast actuators are collapsed and the panels and attached curtains are folded so that the M1128 dimensions are: 65.7 inches (1669 mm) tall by 58.9 inches (1497 mm) long and 27.3 inches (694 mm) wide; able to easily fit through standard hospital doorways.

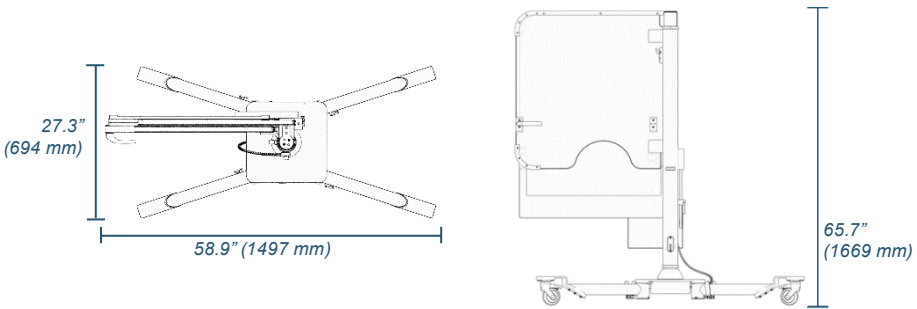

WARNING!

Before transport, the Rampart^{IC} M1128 must be in *Transit Mode* (p. 15) and disconnected from charging.



WARNING:
Tipping
Hazard

- **CONFIGURATION DURING USE:** Panels and attached curtains can be placed safely at any needed angle during use, *so long as one leg is positioned in the general direction of each panel* to provide proper weight distribution and stabilization of the equipment, and to prevent the equipment from tipping.
- **CONFIGURATION DURING TRANSIT:** To move the M1128 to another location, the M1128 must be placed into *Transit Mode* (p. 15). First, the mast must be collapsed to the lowest position and the panels and curtains folded together and locked forward between legs 1 and 4. Then, all four legs should be positioned for Transit with leg locks locked into place to prevent legs from changing angle during transit. The person moving the device should carefully walk on the side of the device with Rampart^{IC} logo to push and guide the M1128 during transit. When in Transit Mode and moved correctly, the M1128 is narrow enough to fit through standard walkways.



CAUTION:
Heavy
Equipment-
Injury Risk

- The M1128 is heavy and caution must be used when handling the system.
- Failure to maintain control when moving the system can result in personal injury or property damage.
- Personnel working with the M1128 system(s) must be properly trained.



CAUTION:
Trip Hazard

- **CONFIGURATION DURING TRANSIT:** To avoid becoming a tripping hazard, the M1128 must be placed into *Transit Mode* (p. 15). First, the mast must collapse to the lowest position and the panels and curtain attachments folded together and locked forward between legs 1 and 4. Then, all four legs should be positioned for Transit with leg locks locked into place to prevent legs from changing angle during transit. When in Transit Mode, the M1128 is stable, narrow enough to fit through standard walkways. The person moving the device should carefully walk on the side of the device with Rampart^{IC} logo to push and guide the M1128 during transit.
- Always maintain awareness of the positioning of M1128 legs and casters to avoid tripping when moving around the M1128.

Note: A training video demonstrating configuration into Transit Mode is available at www.RampartIC.com/training.

TO MOVE IN TRANSIT MODE

1. Remove and set aside the charging cord.
2. **Fold up the CMA curtain** by hooking the curtain hook located on the bottom of the curtain onto the CMA curtain bar.
3. **Unlock the CMA curtain** for movement by turning the CMA clamping handle straight up.
4. Raise the CMA curtain to the highest vertical position.
5. Lock the CMA clamping handle by turning it straight down.
6. Put both rotation locks on the mast into **mid-position auto lock mode**.

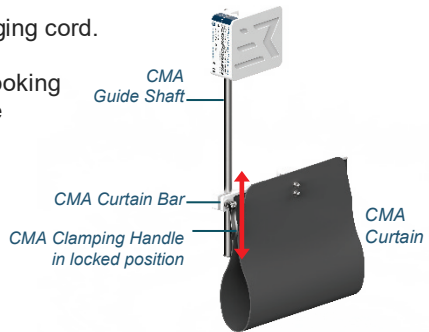

Lower Rotation Lock



Upper Rotation Lock

7. **Lower all panels and curtains** using the *Handset Controller* (p. 23).

8. Fold the radial panel, the lower extremity panel and CMA curtain together between legs 1 and 4. Both rotation locks will automatically lock when panels are in the correct position.



9. **Unlock all casters** by pressing the top half of the tab on each caster lock.

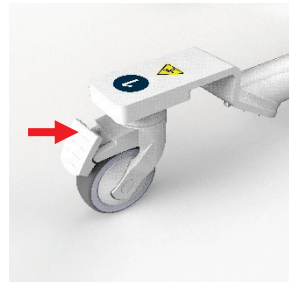

10. **Unlock all four legs** by turning the leg lock **down** on each leg.

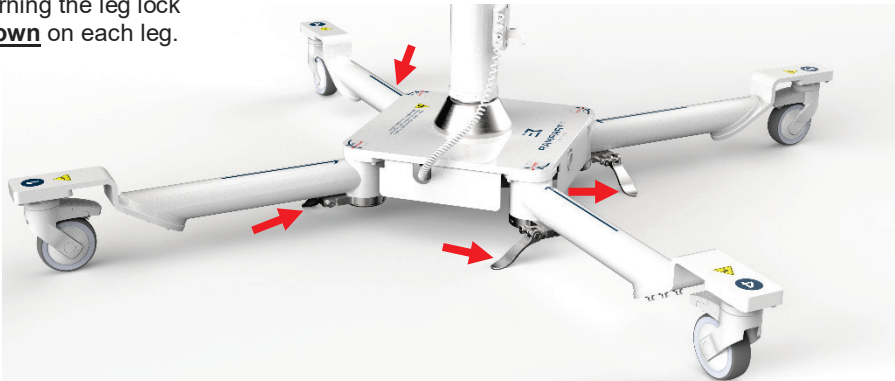

11. **Position all four legs into Transit** position according to the **leg angle labels** adhered to the base of the M1128. When positioned according to these labels, the legs fully support the panels and curtains while properly balancing the M1128 for transit.



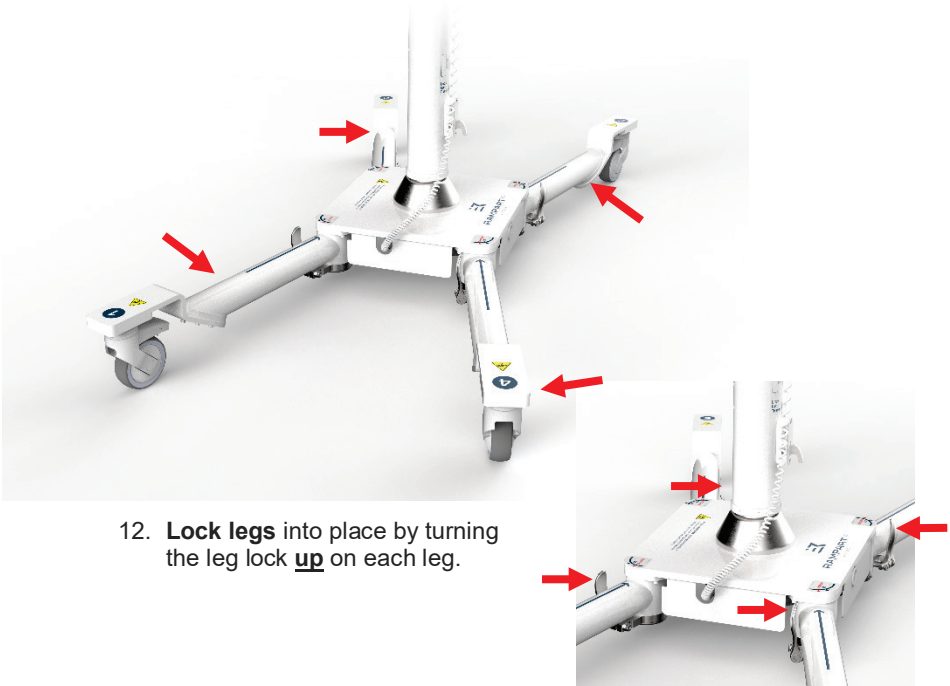

12. Lock legs into place by turning the leg lock **up** on each leg.

13. Make sure all doors between the current location and the destination are unlocked and opened.
14. Make sure that the pathway to the destination is unobstructed.
15. Alert individuals in proximity that equipment is coming through.
16. Stand on the side of the M112B with the **Rampart^{IC} logo**.
17. Secure the equipment by placing one hand on the **mast** and the other hand on the **folded panels**.
18. Walk with the M112B, guiding and pushing it to the desired location.
19. Lock casters upon arriving to destination.

Charging

The M1128 radiation shield is powered by a rechargeable battery designed to be charged only when the M1128 is not in use or in transit.

- Though it takes 10 hours for the M1128 to fully charge, it is recommended that the M1128 remain plugged in continuously—if not in use or in transit—to maintain a full charge.
- Continuous beeping from the battery indicates low charge and need for charging. Continuously charging an M1128 in storage will not damage the battery.
- It is important to battery life to charge the M1128 in full at least once every 12 months.



CAUTION!

- The M1128 must be fully charged at least once every 12 months.
- The M1128 must be charged 10 hours to obtain full charge.
- Always unplug the M1128 radiation shield prior to transport and before use.

1. Move the M1128 radiation shield to *Storage (see p. 31)* or another safe location out of the way of foot traffic and activity, and where there is a standard wall outlet. See *Transit Mode (p. 15)* for directions on how to safely move the M1128.
2. Connect the charging cord to the base of the M1128.
3. Connect the other end of charging cord to the wall outlet.
4. Charge for a **minimum of 10 hours** to obtain a full charge.
Note: *The M1128 can remain plugged in whenever not in use to safely maintain a full charge.*
5. When charged and needed, unplug the M1128 radiation shield before moving and place in *Transit Mode (p. 15)*.

LED INDICATOR - BATTERY STATUS

There is an LED indicator on the edge of the battery affixed to the bottom-side of the M1128 base. The appearance of the LED indicates battery charge status as follows:

LED	Battery Status Indication
Solid light	Battery is charging.
Light off	Battery is fully charged.
Flashing light	There is a charging error.

Instructions for Use

The four legs, extendable mast, acrylic panels and attached curtains of the M1128 can be arranged in a variety of configurations to accommodate patient positions, specific access points, technician location, multiple procedure table types, and other lab equipment in various procedures. The M1128 can also be folded down to *Transit Mode* (p. 15), providing a minimal footprint for safe and efficient movement between rooms.

The M1128 operates on battery power only.

INTENDED USER GROUP

The intended user group for the Rampart M1128 radiation shield are physicians and their staff.

INTENDED PATIENT POPULATIONS

The Rampart M1128 is indicated for any interventional procedure that utilizes fluoroscopy where an operator stands on the right side of the procedure table and uses the following specific access points: bi-radial, bi-femoral, pedal, popliteal, and brachial.

CONTRAINDICATIONS, WARNINGS AND CAUTIONS

Contraindications include internal jugular and axillary access points and emergent TAP procedures.

Note: A training video demonstrating usage tips is available at www.RampartIC.com/training.



**WARNING:
Radiation
Exposure**

- Failure to set M1128 panels and curtains at the proper height and position may cause unwanted radiation exposure. The M1128 is designed to be used with under-table and above-table lower body protection.
- According to the *Expert Consensus Document on Optimal Use of Ionizing Radiation in Cardiovascular Imaging*⁴, proper radiation protection is in place when a minimum of 0.5 mm lead equivalency is placed between the radiation source and medical personnel. When used correctly, the Rampart^{IC} M1128 acrylic panels provide a protection level of 1 mm lead equivalency and the curtains provide 0.5 mm lead equivalency against radiation exposure.
- The acrylic panels and curtains must be handled with care so they are not damaged due to contact with other objects. If the panels or curtains are damaged, they must be rechecked according to the *Maintenance* section (p. 29).

4 J. W. Hirshfeld and V. A. Ferrari, "2018 ACC/HRS/NASCI/SCAI/SCCT Expert Consensus Document on Optimal Use of Ionizing Radiation in Cardiovascular Imaging: Best Practices for Safety and Effectiveness," 2018, <http://www.onlinejacc.org/content/early/2018/04/30/j.jacc.2018.02.016> (accessed August 10, 2019).



**WARNING:
MR-Unsafe**

The M1128 system is MR-unsafe. MR-unsafe items should not be brought into MRI scanner rooms.



**CAUTION:
Heavy Equipment-
Injury Risk**

- The M1128 is heavy and caution must be used when handling the system.
- Failure to maintain control when moving the system can result in personal injury or property damage.
- Personnel working with the M1128 system(s) must be properly trained.



CAUTION

Potential drag may occur when the curtain is moved during a procedure. Ensure that the soft shield flaps are lying flat against the patient's abdomen, pointing towards the patient's head, to allow for the best visibility and intervention to access points.

SAMPLE CONFIGURATIONS



Transit Mode with mast fully collapsed, panels and curtains folded together between legs 1 and 4, and legs in transit mode

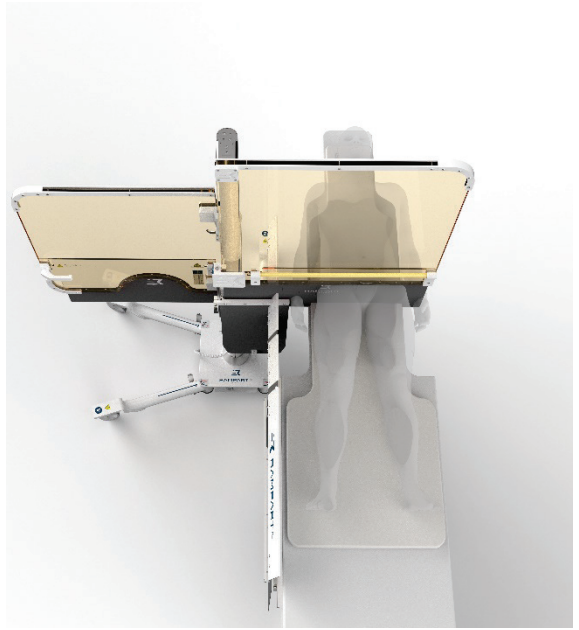

Panels and curtains at 180 deg for radial (bi-radial) and femoral procedures and to accommodate biplane angles.

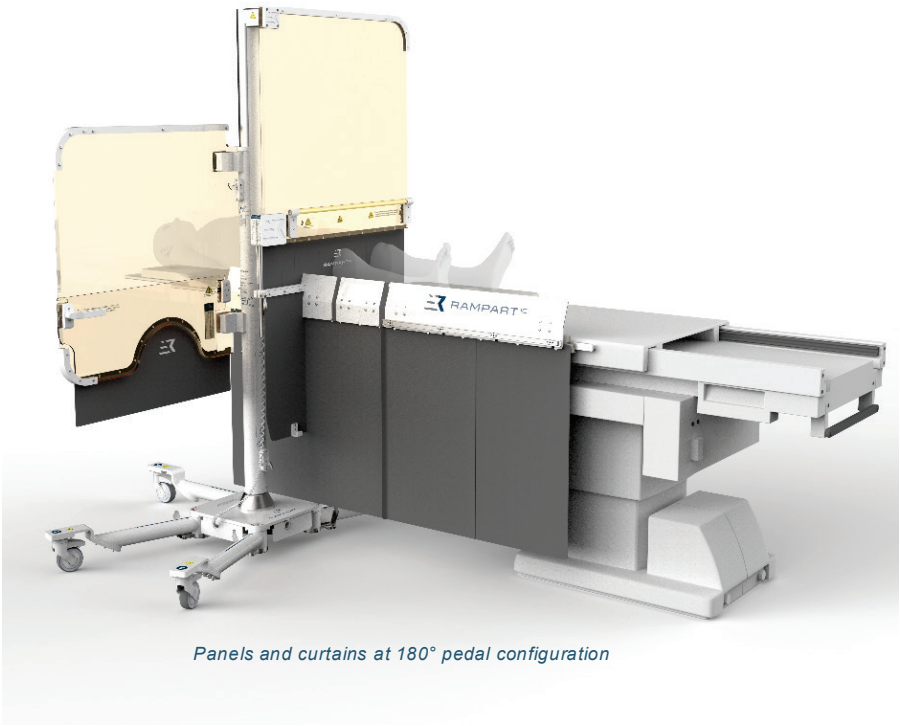

Panels and curtains at 180° pedal configuration

HANDSET CONTROLLER



WARNING:
Rare Earth Magnet

Keep rare-earth magnets away from anyone with a pacemaker and away from magnetic media. Dispose of rare-earth magnets in compliance with local, state and Federal law.

The handset controller accompanying the M1128 is used to raise and lower the procedures and circumstances.

- The **top row of buttons** raises or lowers both panels and curtains simultaneously.
- The **bottom row of buttons** raises or lowers the lower extremity panel only.
- The **controller has a magnet** on the back to increase placement options and convenience.

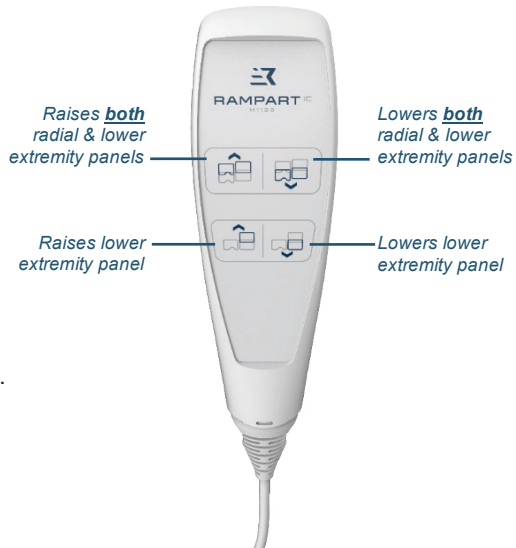

Resetting the Handset Controller

An **intermittent beeping sound** coming from the controller and **inability to move panels upwards** indicates the handset controller is overloaded and needs to be reset.

To reset the handset controller:

1. Hold down **both bottom buttons** on the handset controller for a few seconds until you hear two beeps.
2. Confirm that the overload error has cleared by attempting to lower or raise the lower extremity panel.
3. Repeat **step 1** as necessary.

USING THE M1128



WARNING:
Radiation
Exposure

- Failure to set M1128 panels and curtain attachments at the proper height and position may cause radiation exposure. The M1128 is designed to be used with under-table and above-table lower body protection.
- According to the *Expert Consensus Document on Optimal Use of Ionizing Radiation in Cardiovascular Imaging*⁵, proper radiation protection is in place when a minimum of 0.5 mm lead equivalency is placed between the radiation source and medical personnel. When used correctly, the Rampart^{IC} M1128 panels provide a protection level of 1 mm lead equivalency and the curtains provide 0.5 mm lead equivalency against radiation exposure.
- The acrylic panels and curtains must be handled with care so they are not damaged due to contact with other objects. If the panels or curtains are damaged, they must be rechecked according to the *Maintenance* section on page 29 of this user guide.

1. Unlock the M1128 casters if they are locked.



CAUTION!

Locking the casters during a procedure may cause damage to the M1128 or interfere with its proper use.

2. **Position M1128 legs** according to the type of procedure, planned panel and curtain assembly orientation, and in a way where each panel and curtain will be directly supported by a leg. To adjust each leg individually:

- a. **Unlock the legs** by turning the leg lock down on each leg.

- b. **Move legs into desired positions.**

- **Legs 1, 3 and 4** can be adjusted between 17.8 and 45 degrees.
- **Leg 2** can adjusted between 17.8 and 90 degrees.

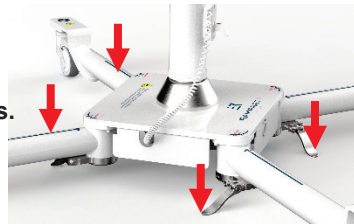

- c. **Lock the legs** by turning the leg lock up on each leg.

Note: *It is recommended that M1128 legs are placed in the optimal position prior to advancing to the table as predetermined and optimized for the particular operator and access point. The M1128 leg position can be configured to fit most procedures, table types and the comfort of the medical team, and is positioned by feet to maintain hand sterility.*

5 J. W. Hirshfeld and V. A. Ferrari, "2018 ACC/HRS/NASCI/SCAI/SCCT Expert Consensus Document on Optimal Use of Ionizing Radiation in Cardiovascular Imaging: Best Practices for Safety and Effectiveness," 2018, <http://www.onlinejacc.org/content/early/2018/04/30/j.ajcc.2018.02.016> [accessed August 10, 2019].

3. **Unlock the lower extremity panel** by pulling the **upper rotation lock** to its furthest position out away from the mast.

Upper
Rotation
Lock



4. Rotate the lower extremity panel into the desired position. *The lower extremity panel can open a maximum of 210 degrees.*

Note: *The upper rotation lock must be unlocked and the lower extremity panel opened to at least a 90-degree angle before panels can be raised. Once raised, the lower extremity panel cannot be rotated less than 90-degrees; the panels must be lowered all the way with the handset controller before panels can be folded together into transit position.*

5. **Using the handset controller**, adjust the M1128 panels and curtain attachments to the approximate height of the anticipated access site (radial, femoral, pedal, or otherwise) when the patient is eventually positioned.
6. Place or attach the handset controller in a location that is convenient on the M1128.
7. Adjust the rotation of the lower extremity and radial panel so that they are in correct positioning for the procedure.

- **CONFIGURATION DURING USE:** Panels and curtain attachments can be placed safely at any needed angle during use, so long as one leg is positioned in the general direction of each panel and curtain to provide proper weight distribution and stabilization of the equipment, and to prevent the equipment from tipping.
- **CONFIGURATION DURING TRANSIT:** To move the M1128 to another location, the M1128 must be placed into *Transit Mode (p. 15)*. First, the mast must be collapsed to the lowest position and the panels and curtains folded together and locked forward between legs 1 and 4. Then, all four legs should be positioned for Transit with leg locks locked into place to prevent legs from changing angle during transit. The person moving the device should carefully walk on the side of the device with RampartIC logo to push and guide the M1128 during transit. When in Transit Mode and moved correctly, the M1128 is stable, narrow enough to fit through standard walkways.



WARNING:
**Tipping
 Hazard**

8. **Unlock the CMA curtain** for vertical adjustment by turning the CMA clamping handle **straight up**. The unlocked CMA curtain can be adjusted up and down the CMA guide shaft.
9. Vertically adjust the CMA curtain by moving the CMA curtain bar to the anticipated height needed and **lock** the curtain by turning the CMA clamping handle **straight down**.

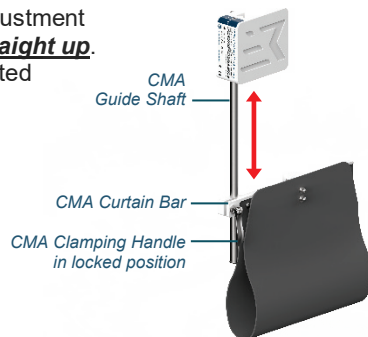

10. **Orient the CMA accessory curtain** to the anticipated position reflecting the access site and patient position.

11. Follow *Drape Instructions* (steps 12 through 22 in the next section) to place sterile drapes over the M1128 radiation shields, the radiation shielding soft accessory kit (M1128-RAK), and the center mast accessory (M1128-CMA). **Skip steps 13 and 14 for Drape 2 if the center mast accessory is not included in your purchase.**



- **Remove drapes 1, 2, 3 and 4 from package** and place them on the scrub table. The drapes are packaged and numbered in the order they should be applied with application instructions on the labels.
- **Apply drapes 1, 2, 3 and 4** according to the instructions on the labels.
- Do not over cinch the pull cords.
- Allow the drape to adequately encompass the curtains without compressing the curtain flaps.

Drape Instructions

<u>Drape 1:</u> Left Drape	12. Place drape 1 over the <u>radial panel</u> and the <u>radial curtain</u> .
<u>Drape 2:</u> Lower Drape	13. Place drape 2 over the entire <u>CMA assembly</u> starting from the bottom of the accessory moving up over the top. 14. Tighten the blue drawstring on top of the CMA assembly.
<u>Drape 3:</u> Right Drape	15. Place drape 3 over the <u>lower extremity panel</u> , <u>top of mast</u> , and the <u>lower extremity curtain</u> . 16. Tighten the gray drawstring. Note: Make sure the cord lock and drape cord do not touch the mast.
<u>Drape 4:</u> Center Drape	17. Remove the top left adhesive tape backing from drape 4. 18. Place the left adhesive on the top back of the radial panel and curtain, about 8" from the <u>mast</u> . 19. Remove the top right adhesive tape backing from drape 4. 20. Place the right adhesive tape on the top back of the lower extremity panel and curtain, about 8" from the mast, making sure to maintain slack along the top of drape 4 and between the left and right adhesive. Note: Maintaining slack at the top of drape 4 allows for adjustability of the mast and avoids causing tension on the adhesive tabs. 21. Remove the rest of the adhesive backings from drape 4. 22. Secure the rest of the drape 4 backings to completely cover the mast.

Note: Drapes are sold separately at Rampart^{IC} and not included with purchase of the M1128. A training video demonstrating how to use the drape kit is available at www.RampartIC.com/training.

23. **Further adjust the radial panel, the lower extremity panel and attached curtains** with the handset controller while considering the access site, patient position and size, table height, and physician's preference.
24. Ensure proper lower table and lower body radiation protection is in place at the procedure table.
Note: Rampart^{IC} recommends using under-table lead-equivalent curtains that fully extend between the radiation source and the positions of the medical team during a procedure.
25. Position the patient for the procedure.
26. Drape the patient and table as usual.
27. **Lower the procedure table** in preparation for precise positioning of the M1128, as necessary.
28. Roll the M1128 to adjust physical orientation, as necessary.
29. **Raise the procedure table** to meet the M1128 radiation shield, as necessary.
30. **Further customize the positioning of the M1128** mast, panels and curtains after the patient, staff, other equipment, and the physician are in position.



CAUTION:
Pinch Point

When making final adjustments to the M1128 and while the patient is in position, always monitor the lower edge of the panel and curtain in relation to the patient to prevent injury. Always maintain visual contact with panels, curtains and other equipment, in relation to the patient, when panels, curtains or other equipment are being adjusted.

31. **Position Rampart^{IC} anti-fatigue mat(s)** according to the comfort of physician and staff.

Note: A Rampart^{IC} anti-fatigue mat is provided with each M1128. To purchase additional anti-fatigue mats, email info@RampartIC.com.

32. Place scrub table and fluoroscopy handset controllers and control pedals in place on the floor keeping in mind the location of M1128 leg position, physician preference and safety.



CAUTION:
Trip Hazard

- Failure to place controllers and the M1128 legs in a convenient and safe position can result in a tripping hazard for the physician and medical team in the lab.
- Always maintain awareness of the positioning of M1128 legs and casters to avoid tripping when moving around the M1128.

33. **Conduct a safety check** to ensure all radiation protection equipment is in place and radiation gaps below table and around the M1128 radiation shield are minimized.
34. **Make final adjustments** to the M1128 as necessary.
35. Conduct fluoroscopic procedure.
36. When the procedure is complete, **adjust the M1128 mast, panels and curtains with the handset controller so that it can be pulled away** from the procedure table without harming the patient or equipment.



WARNING:
Tipping Hazard

- **CONFIGURATION DURING USE:** M1128 panels and attached curtain assemblies can be placed safely at any needed angle during use, *so long as one leg is positioned in the general direction of each panel and curtain* to provide proper weight distribution and stabilization of the equipment, and to prevent the equipment from tipping.
- **CONFIGURATION DURING TRANSIT:** To move the M1128 to another location, the M1128 must be placed into *Transit Mode (p. 15)*. First, the mast must be collapsed to the lowest position and the panels and curtains folded together and locked forward between legs 1 and 4. Then, all four legs should be positioned for Transit with leg locks locked into place to prevent legs from changing angle during transit. The person moving the device should carefully walk on the side of the device with Rampart^{IC} logo to push and guide the M1128 during transit. When in Transit Mode and moved correctly, the M1128 is stable, narrow enough to fit through standard walkways.



CAUTION:
Pinch Point

When making final adjustments to the panels and curtains, and while the patient is in position, always monitor the lower edge of the panel and curtain in relation to the patient to prevent injury. Always maintain visual contact with panels, curtains and other equipment, in relation to the patient, when panel and curtain assembly or other equipment are being adjusted.

37. Carefully roll the M1128 away from the patient enough so patient can be safely removed.
38. **Remove patient** from the procedure room.
39. **Dispose used drape kit** according to standard biohazard guidelines.
40. **Clean** (see *Cleaning on p. 29*) and **store** (see *Storage on p. 31*) the M1128.
41. Follow directions in this user guide for moving the M1128 in *Transit Mode (p. 15)*.

Maintenance

The Rampart^{IC} M1128 requires post-procedure cleaning, routine inspections and repairs by Rampart^{IC} authorized personnel to maintain optimal performance.



CAUTION:
Heavy
Equipment-Injury
Risk

- The M1128 is heavy and caution must be used when handling the system.
- Failure to maintain control when moving the system can result in personal injury or property damage.
- Personnel working with the M1128 system(s) must be properly trained.
- M1128 assembly, repairs and maintenance may only be performed by Rampart^{IC} personnel or people authorized by Rampart^{IC}.

CLEANING

The Rampart^{IC} M1128 must be thoroughly cleaned and disinfected in accordance with standard operating room practices and CDC guidelines. Clean each component after use and prior to maintenance. Always use disposable drape kits to maintain sterility during procedures and dispose of them after.



CAUTION:
Heavy
Equipment-
Injury Risk

- The M1128 is heavy and caution must be used when handling the system.
- Failure to maintain control when moving the system can result in personal injury or property damage.
- Personnel working with the M1128 system(s) must be properly trained.
- M1128 assembly, repairs and maintenance may only be performed by Rampart^{IC} personnel or people authorized by Rampart^{IC}.



CAUTION!

- When cleaning acrylic panels and curtains, never use rough or abrasive-faced sponges, steel wool, brushes, or cleaning pads.
- When cleaning any component of the M1128, never use scrapers or metal tools of any kind.

The M1128 acrylic panels and curtains will be permanently damaged if cleaned with abrasive cleaners. **When cleaning acrylic panels and curtains, DO NOT clean with the following cleaning supplies:**

ATTENTION!

- Paper towels or linen washcloths
- Alcohol wipes
- Sporidican⁶ Disinfectant Towelettes
- Rough or abrasive-faced sponges, brushes, cleaning pads, scrapers, or metal tools
- Strong detergents or abrasives such as scouring powders
- Aerosol cleaners with Butyl Cellosolve⁷
- Hydrocarbon or chlorinated solvents, ammonia (more than 0.5%), or strong alkali cleaners
- Cleaners that are designed for grease cutting
- Excessively hot water or steam

Cleaning

Clean the M1128 by wiping it with a soft cloth and a neutral pH enzymatic detergent (typically pH 6-8) diluted in water.

Disinfection

Disinfect the M1128 using one of the following:

- 70% or less isopropyl alcohol
(Dry panels and curtains immediately after application.)
- Sani-HyPerCide⁸ Germicidal Disposable Wipe
- Super Sani-Cloth⁹ Germicidal Disposable Wipes
- CaviWipes¹⁰ 2.0 Disinfecting Wipes

Notes:

- *Always use detergent or wipe products according to safety precautions and use directions provided by the manufacturer.*
- *The use of disinfecting products may cause panel discoloration over time.*
- *Rampart^{IC} cleaning cloths are designed for safely cleaning M1128 panels and curtains and are available for purchase. To purchase, email info@RampartIC.com.*

6 Sporidican® is a registered trademark of Contec, Inc.

7 Butyl Cellosolve™ is a trademark of the Dow Chemical Company.

8 Sani-HyPerCide® is a registered trademark of PDI.

9 Super Sani-Cloth® is a registered trademark of PDI.

10 CaviWipes® is a registered trademark of Metrex Research LLC.

STORAGE

Rampart^{IC} recommends transporting and storing the M1128 in *Transit Mode* (p. 15) due to the stability and minimal space footprint of this configuration.

1. Make sure the M1128 is cleaned (see *Cleaning* on p. 29) before storage.
2. Move the M1128 in *Transit Mode* (p. 15) to a dedicated storage room, to the side of the cath lab or other suitable location where there is minimal foot traffic and activity, and where there is a standard wall outlet.
3. Plug in the rechargeable battery to charge when the M1128 is not in use. See *Charging* on page 19.

Note: *The M1128 should remain plugged in whenever not in use to safely maintain a full charge.*



CAUTION!

- The M1128 must be fully charged at least once every 12 months.
- The M1128 must be charged 10 hours to obtain full charge.
- Always unplug the M1128 radiation shield prior to transport and before use.

PREVENTATIVE INSPECTION

Rampart^{IC} recommends an annual preventative maintenance inspection by a Rampart^{IC} authorized representative.

1. Make sure the M1128 is cleaned (see *Cleaning* on p. 29) before performing preventative inspection.
2. Inspect panels, curtains, mast and mobile unit to ensure:
 - a. All parts are fastened tightly.
 - b. The casters roll smoothly.
 - c. The support legs adjust easily.
 - d. There are no cracks or damage to any of the panels and curtains.
 - e. The panels and curtain attachments rotate easily around the mast.
 - f. The actuators function well in raising and lowering each panel and curtain attachment.
3. Preventative maintenance following the equipment specific maintenance plan will default to the policies and procedures of the institution related to inspecting shielding. Rampart service team will perform a visual inspection of attenuating components to determine appropriateness. If institution participation is available to operate fluoroscopic equipment, such testing will be performed via institution staff.
4. The Rampart^{IC} authorized representative will perform or schedule repairs necessary including ordering replacement parts.

PARTS AND ACCESSORIES

Part Number	Description
M1128-RTV	M1128 Radiation Shield Right Table Version V2
M1128-CDK	M1128 Drape Kit
M1128-UIG	M1128 User and Installation Guide
M1128-AFM	M1128 Antifatigue Mat
M1128-RCC	M1128 Rampart Cleaning Cloth

SUGGESTIONS

Adjustable Legs

The legs of the M1128 are adjustable to accommodate a number of needs and scenarios. Rampart^{IC} has added leg numbers and leg angle indicator labels to the M1128 base for easy reference. It may be helpful and more efficient for staff to use the angle indicator labels and numbering on the legs to note the leg placement preferences of different physicians and what works best for different procedures.

Before transit, all four legs should be moved into Transit position and locked to prevent them from changing angles during movement. Upon arrival to the cath lab, the leg locks can be unlocked for adjustment as necessary. The physician or technician can keep their hands sterile by adjusting unlocked legs with their feet.

Under & Above Table Lower Body Protection

Rampart^{IC} requires the use of a below-table lead-equivalent protective shield in conjunction with the M1128 radiation shield such as the Rampart^{IC} L148 table-mounted shield available for purchase through Rampart^{IC}. When used in the correct configuration, the physician and the lab technician will be shielded from 98% to 99.9% radiation exposure. This facilitates freedom of movement during a procedure for the staff and physician.

Transit Mode

To ensure easy transportation from room to room, the M1128 should always be configured into *Transit Mode* (p. 15) prior to being moved. This position is when the radial panel, lower extremity panel and attached curtains are in their lowest position and folded in together pointing forward. All four legs should be placed in the Transit Mode as indicated by the leg arrow and the leg angle label, and the legs should be locked. Transit Mode is also the ideal storage position due to its maximum stability and smaller footprint.

When repositioning the M1128 out of Transit Mode, first unlock the legs. Then move all legs to the 45° angle as shown on the leg angle labels. Panels and attached curtains can then be moved into desired position. Legs can be placed in position for the procedure after panel and curtain positioning, but there must always be one leg positioned in the general direction of each panel and curtain to ensure proper M1128 balance and stability.

LIMITED WARRANTY

Rampart^{IC} warrants to Customer that this product, manufactured by Rampart^{IC} and sold to Customer, will be free from defects in materials and workmanship for a period of one (1) year after delivery to Customer. This warranty shall not apply to any products which have been subjected to misuse, improper installation or repair, alteration, neglect, accident, abnormal conditions of operation, or use under conditions other than those for which the products were designed.

EXCEPT FOR THE FOREGOING LIMITED WARRANTY, SELLER MAKES NO OTHER WARRANTIES, EITHER EXPRESSED OR IMPLIED, INCLUDING ALL WARRANTIES OF FITNESS OR OF MERCHANTABILITY.

DISPOSAL



WARNING:
Rare Earth
Magnet

Keep rare-earth magnets away from anyone with a pacemaker and away from magnetic media. Dispose of rare-earth magnets in compliance with local, state and Federal law.

The Rampart^{IC} M1128 system contains lead-equivalent panels, lead-equivalent curtains, rare earth magnets and a rechargeable battery. The system and all components should be disposed of in an environmentally safe manner per local, state and Federal laws.



RAMPART IC

M1128

1500 Urban Center Drive, Suite 140, Birmingham, Alabama USA
(205) 236-3000 Office, (833) 978-0052 Technical Support

info@RampartIC.com

www.RampartIC.com

EC REP



CS Lifesciences Europe, Limited
The Black Church, St. Mary's Place
Dublin 7, Dublin, D07P4AX, Ireland
eurep@cslifesciences.com

